

Application of The FR-04 Sensor for Automatic and Energy-Saving Clothesline Roof Control

Morina Buulolo^{1)*}, Carles Wiranto Laia²⁾, Nafaoli Buulolo³⁾, Roberto Kaban⁴⁾, Rimmar Siringo-tingo⁵⁾
¹⁾²⁾³⁾⁴⁾⁵⁾Fakultas Sains dan Teknologi, Teknik Informatika, Institut Teknologi dan Bisnis Indonesia
¹⁾buulolomorina@gmail.com, ²⁾carleswirantolaia@gmail.com, ³⁾buulolonafaoli@gmail.com,
⁴⁾roberto.kaban@yahoo.com, ⁵⁾rimmarsiringo1@gmail.com

Submitted :24 October 2025 | **Accepted** : 21 November 2025 | **Published** : 30 November 2025

Abstract: The application of the FR-04 sensor for automatic and energy-saving clothesline roof control is based on problems that people who have clothesline, so that dry clothes become wet with rainwater when the occupants of the house are outside the house. This system uses an FR-04 sensor to detect rain and an Arduino Uno microcontroller to control the Stepper Motor which opens and closes the clothesline roof. It is hoped that the creation of an automatic clothes drying roof design will help people reduce their anxiety when drying clothes in the rainy season.

Keywords: Clothesline; FR-04 Sensor; Arduino Uno; Stepper Motor; Rain

INTRODUCTION

In order to support human life, the use of natural resources remains the primary choice. One of these resources is sunlight. Sunlight is used to assist human activities. For example, in industry, sunlight can be used to make salt or to dry salted fish (Hafidhin et al., 2020). Even on a small or household scale, sunlight is usually used to dry laundry or clothes.

Clotheslines are one of the means used to dry clothes. Clotheslines are usually placed outdoors, so that the clothes being dried are exposed to sunlight and rain. Exposure to sunlight and rain can cause clothes to become dull and damaged. One way to prevent clothes from becoming dull and damaged is to dry them when the weather is sunny and cover the clothesline when it rains (Putra & Wicaksono, 2022). However, this requires vigilance and timing on the part of the homeowner. If the homeowner forgets to cover the clothesline when it rains, the clothes will get wet and become dull.

To overcome this problem, a system is needed that can automatically close the drying roof when it rains. A rain sensor is one type of sensor that can be used to detect rain. Rain sensors work by detecting changes in air humidity (Mustar, 2017). When it rains, air humidity increases. A rain sensor then detects this change in humidity and sends a signal to a controller. This system is designed as a solution to the challenges of manually drying clothes. This system saves time and effort, protects clothes from rainwater, and provides comfort for users, eliminating the need to worry about clothes getting wet when it rains.

Significantly different from previous research, which generally only used simple rain sensors to detect air droplets directly, this research combines air humidity sensors and rain sensors to predict the arrival of rain well in advance before the air hits the clothes (Susanto & Priyanto, 2022). Furthermore, the developed system is equipped with automatic control based on a microcontroller and motor actuators, allowing the clothesline to automatically move to a shaded area without user intervention (Rahman & Anwar, 2023). Thus, this research focuses not only on rain detection but also on intelligently and efficiently automating clothing protection, thus offering a higher level of brightness and comfort than previous systems (Nguyen & Le, 2021).

LITERATURE REVIEW

1. Automatic Clothes Drying Roof

An automatic clothesline roof is a system designed to open and close the clothesline roof automatically based on data from installed sensors. According to Syarmuji et al. (2022), this system functions to control the clothesline roof so that it can open and close automatically according to the intensity of sunlight or rainfall. The sensors used generally consist of light sensors (LDR) and water sensors that work synergistically in detecting environmental conditions.

* Morina Buulolo, et al



Lenni and Ajis (2018) explain that the automatic drying roof system uses an FR-04 sensor to detect water droplets on the sensor surface. When water is detected, the system closes the roof, while when the sensor surface is dry, the roof reopens. This system is controlled by a microcontroller and a servo motor as an actuator to move the roof automatically.

The existence of automatic clothes drying roofs provides several benefits in everyday life. First, this system can reduce people's concerns when drying clothes during the rainy season, especially for those who are active outside the home (Lenni & Ajis, 2018). Second, the use of this system can save time and energy because users do not need to move clothes repeatedly when it rains (Mochammad Asy'ari et al., 2019). Third, the risk of damage to clothes due to rain can be minimized because the system can automatically close the roof when the sensor detects rainwater (Mufida & Abas, 2017). Thus, the automatic drying roof system is an effective solution that combines convenience, efficiency, and protection against weather conditions.

2. Sensor FR-04 Sensor

The FR-04 sensor is a type of rain sensor that works on the principle of water conductivity. Based on research by Umar et al. (2023), rain sensors are made by utilizing the electrolytic properties of water, which can conduct electricity. When rainwater hits the sensor surface, an electrolysis process occurs, causing the circuit to become active. This sensor is usually made using a PCB board with winding paths so that falling water can connect these paths and conduct electricity. To maintain reliability, the PCB paths are coated with tin to prevent rust or dirt that can inhibit conductivity.

According to Nasution et al. (2023), the FR-04 sensor functions to detect the presence of water on its surface and generate an output voltage that can be sent to a microcontroller such as Arduino Uno. In an automatic clothesline system, when the FR-04 sensor detects rainwater, the system will send a signal to automatically close the clothesline roof to protect clothes from getting wet. The application of this sensor has proven to be efficient in supporting time- and labor-saving home automation systems (Umar et al., 2023).

3. Energy Conservation Concept

Energy conservation is an effort to reduce inefficient energy consumption through the wise and effective use of energy resources. Khulaemi (2022) defines energy conservation as any form of action aimed at reducing expenses resulting from excessive energy use. Energy conservation practices play an important role in reducing the nation's ever-increasing energy consumption.

Sulistiwati (2021) adds that energy efficiency can be achieved through two approaches, namely the use of efficient technology and changes in user behavior. Meanwhile, Prianto (2020) states that community participation in energy efficiency campaigns helps reduce electricity consumption and minimize negative impacts on the environment. In the context of this study, the concept of energy conservation is applied through the use of solar panels as the main energy source in an automatic clothes drying roof system. According to Junaldy et al. (2019), solar panels are devices that can convert solar radiation energy directly into electrical energy.

In addition, the system also utilizes an LDR (Light Dependent Resistor) sensor to detect light intensity. According to Adi Wisaksono (2020), the resistance in the LDR will decrease when the light received increases, and vice versa, it will increase when the light intensity decreases. This allows the system to automatically adjust its response to lighting conditions. Al Ghifari et al. (2022) also explain that changes in resistance in the LDR sensor can be used to regulate the operation of lights or other automated systems according to the detected light intensity level.

4. Microcontroller

Microcontrollers are key components in automation systems. Dharmawan (2017) explains that microcontrollers are microcomputer chips in the form of ICs (Integrated Circuits) consisting of a CPU, RAM, ROM, and input/output ports. Microcontrollers are used in various electronic devices such as ovens, remote controls, and robots, because they have the ability to control small systems that do not require complex computing. In addition, some microcontrollers are equipped with additional features such as ADC (Analog to Digital Converter), USB Controller, and serial communication, making them ideal for automatic control applications such as automatic clothes drying systems.

5. Arduino Uno

Arduino Uno is one of the most widely used microcontroller boards in research and automation projects. According to Sokop et al. (2016), Arduino Uno is based on the ATmega328 chip and is equipped with 14 digital I/O pins, 6 analog inputs, a 16 MHz crystal oscillator, a USB connector, and a reset button. The Arduino Uno is easy to use because it can be programmed through the Arduino IDE using the Arduino programming language (Zain & Surmayanti, 2016). Obi (2019) states that the Arduino Uno is the best board for beginners in learning electronics and programming because it is flexible and widely used globally.

* Morina Buulolo, et al



In an automatic clothes drying system, Arduino Uno functions as the main controller that receives input from sensors (such as FR-04 and LDR) and provides output to actuators such as servo motors, buzzers, or relays. Stepper motors are used as actuators that convert electrical signals into mechanical motion. Nababan and Sulindawati (2020) explain that stepper motors work on the principle of generating a magnetic field to produce a pulling force that causes the rotor to move in small, precise steps.

A buzzer is used as a sound indicator in the system, which functions to convert electrical signals into sound vibrations (Manurung et al., 2021). The LCD component functions as a data display medium, where according to Budiyo (2012), a 16x2 LCD is used to display numerical information or system status in real time.

Adapters are also an important part of this system. Hafidhin et al. (2020) explain that adapters function to convert AC voltage to DC to suit the needs of electronic devices. Ahdan et al. (2019) and Mulyanto et al. (2021) add that adapters or DC power supplies ensure voltage stability so that the system can operate properly and safely.

METHOD

2.1 Research Stages

To assist and support this research, the following stages were used as guidelines in conducting the research:

1. Laboratory Research (Laboratory Research)

In this method, the author directly creates a working system for a device that can control the simulation of household appliances. In the laboratory, the author tests and verifies the performance of a system, both the hardware and software of the system to be designed.

2. Library Research

In this method, the author cited several readings related to the title raised. The data cited could be theories or opinions from several reading books or books used during lectures. This was intended to provide a strong theoretical foundation through books or literature available in the library, both in the form of lecture materials and other materials related to the thesis title.

2.2 Analysis and Design

In this study, the author analyzed previous research journals as references to assist the author, namely:

2.2.1 Analysis of The Current System

In analyzing the current system of drying clothes on rooftops, it is common for Indonesians to use the sun's heat to dry their washed clothes. However, when the weather is unpredictable, people will spend time and energy just to hang and remove clothes repeatedly. For people who travel frequently, this adds to their worries about the clothes they leave on the drying rack. Therefore, the current method of drying clothes still causes concern when the weather is unpredictable and also for people who travel frequently.

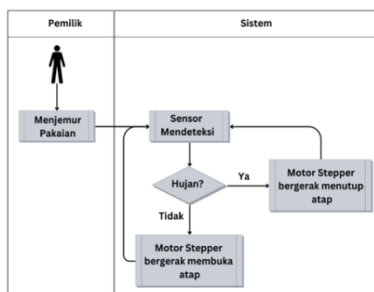

Figure 1. The System in Operation

Based on the analysis of the system shown in the image above, it explains manually how to dry clothes under human supervision. If the weather is sunny, the clothes will dry quickly, and if it suddenly rains while drying clothes, the owner must immediately secure the clothesline.

2.2.2 Analysis of the System Built

The solution to this problem is the need for an automatic clothesline roof mechanism that automatically opens the clothesline roof when the weather is sunny and closes the roof when it rains. Thus, sunlight can be used effectively to dry clothes so that they dry properly.

* Morina Buulolo, et al



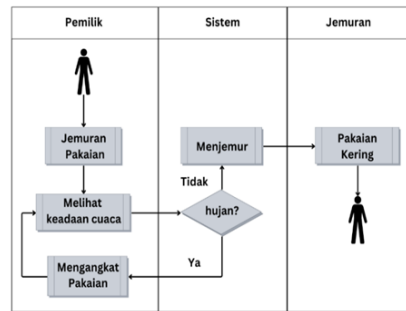

Figure 2. The System Built

2.3 Design

The tool design stage is a follow-up to the analysis results so that a system design required for device manufacturing can be produced. The main objective of this system design is to provide a design image of the system to be built or developed. The following designs will be developed, among others:

2.3.1 System Design

Mechanical design is an important aspect in the manufacture of this tool because referring to this design will make it easier to implement it into its original form. Based on the results of the above analysis, the author continues by creating an illustration or design to be built as follows:



Figure 3. Preliminary Design Draft

Design Specifications :

- a. LCD 16x2
- b. Rain Sensor
- c. Light Sensor
- d. Drive Gear
- e. Stepper Motor
- f. Clothes Drying Rack
- g. Clothesline
- h. Solar Panel

2.3.2 Block Diagram Design

The purpose of designing this block diagram is to facilitate understanding of the working principles of the device to be created. This block diagram explains how the device is activated. The system block diagram consists of several blocks, each of which has a specific function.

Overall, this device consists of inputs, a data processing/control system, and outputs. All input data is programmed by the main programmer, Arduino Uno, which acts as the main controller of all input data, then processed for execution by the outputs.

The block diagram of the automatic clothes drying rack prototype can be seen in Figure 4 below:

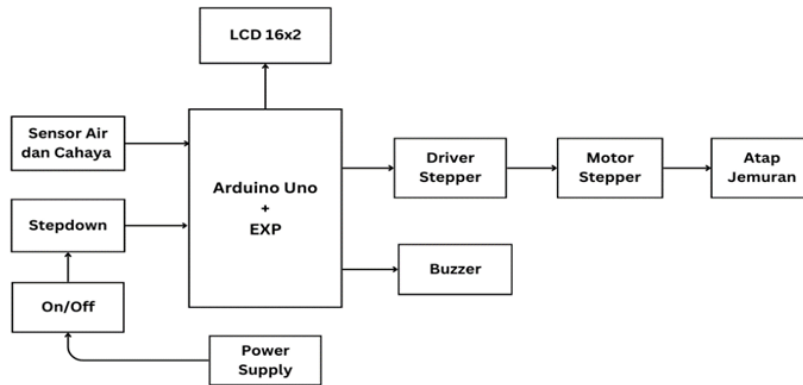

Figure 4. Device Block Diagram

Diagram Description:

- The Rain Sensor functions as a water drop detector and the Light Sensor as a light detector.
- Arduino Uno functions to process data from the FR-04 Sensor and control the Stepper Motor.
- EXP (Expansion) functions to expand the range of the Arduino.
- Power Supply functions to provide electrical power to the system.
- The Step-Down Converter reduces the electrical voltage and adjusts it to the system's requirements.
- The On/Off Button is used to turn the system on and off.
- The Buzzer emits a sound to indicate whether the clothesline roof is open or closed.
- The 16x2 LCD displays the weather conditions and the status of the clothesline roof (open or closed).
- The Stepper Driver converts the electrical signals it receives into motor movement.
- The Stepper Motor functions as the mechanism that drives the clothesline roof to open and close.
- The clothesline roof functions as a mechanical structure that protects the clothes being dried.

2.3.3 System Flowchart Design

A flowchart is a graphical representation that illustrates a step-by-step solution to a problem. Flowcharts are not only used to illustrate simple operations but can also be used to handle complex problems [4]. Figure 5 is a flowchart for an automatic clothes drying roof program:

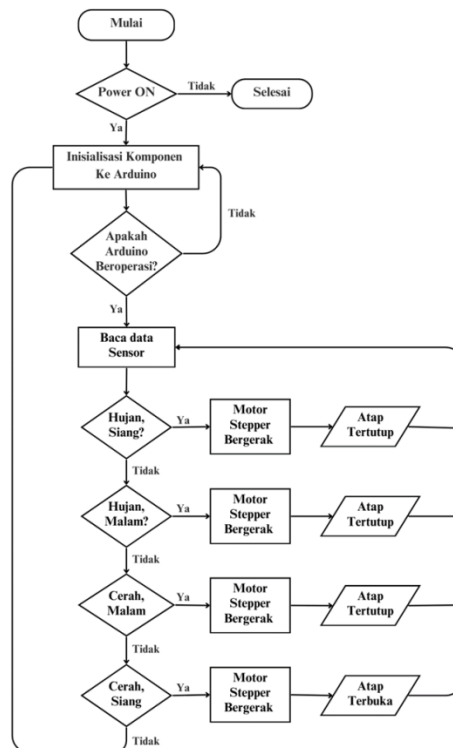

Figure 5. System Flowchart

* Morina Buulolo, et al



The research series or system sequence of this research is that if the tool being assembled has several conditions that will activate the tool, it is as follows:

- a. Rain, Day: The rain sensor detects the presence of rainwater and the light sensor detects the presence of light, then the clothesline roof will be closed.
- b. Rain, Night: The sensor detects the light sensor does not detect any light, so the clothesline roof will be closed.
- c. Sunny, Night: the rain sensor does not detect the presence of rainwater and the light sensor does not detect the presence of light, so the clothesline roof will be closed.
- d. Sunny, Day: The rain sensor does not detect the presence of rainwater, but the light sensor detects the presence of light, so the drying roof opens.

RESULT

3.1 Results

Based on the design results from the system analysis stage, the system design and testing as well as the overall working system of the tools, both software and hardware, have been tested at the ITB Indonesi Robotics Lab and can function as expected, with the following results :

- a. The rain sensor function as a water drop detector and the light sensor as a light detector.
- b. The stepper motor functions as a driver for the clothesline roof so that it can open and close automatically under certain conditions.
- c. The buzzer is used to make a sound as a sign that the clothesline roof is open or closed.
- d. The 16x2 LCD is used to display weather conditions and the status of whether the dring roof is open or closed.
- e. The clothesline roof is designed as a mechanical circuit that protects the clothes to be dried.
- f. The software system design on Arduino functions to process data from the rain sensor and control all systems.

3.1.1 Hardware Design Results

The system design was carried out by assembling all components into a single unit and connecting the existing system to the Arduino Uno using the appropriate cables. All components were connected in an integrated manner to ensure the system could function automatically and efficiently. The connections can be seen in the following table:

Tabel 1. Component connections to Arduino Pin

Rain Sensor	Arduino Uno
D0	D8
GND	GND
VCC	5V
Sensor Cahaya LDR	Arduino Uno
VCC	5V
GND	GND
A0	A0
Motor Stepper	Arduino Uno
VCC	5V
GND	GND
STEP	Digital Pin 8
DIR	Digital Pin 9
LCD 16x2	Arduino Uno
VCC	5V
GND	GND

* Morina Buulolo, et al



SCL	SCL (Analog Pin 5)
SDA	SDA (Analog Pin 4)
EN	Digital Pin 10
RS	Digital Pin 11
D4	Digital Pin 12
D5	Digital Pin 13
D6	Digital Pin 2
D7	Digital Pin 3
Buzzer	Arduino Uno
VCC	5V
GND	GND
OUT	Digital Pin 7

The sensors, consisting of a rain sensor and a light sensor, detect changes in physical phenomena in the surrounding environment, which are then converted into electrical quantities as input to the Arduino. Using the input data from the sensor components, the Arduino then sends command signals to the stepper motor to move the roof to close or open according to the conditions specified in the program. The system circuit display can be seen in Figure 6 below:

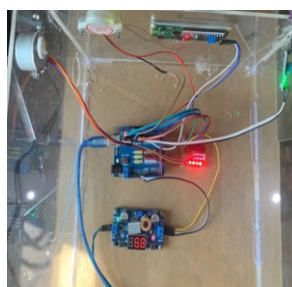

Figure 6. System Prototype Series

The circuit is then combined into a simple miniature house, where the rain sensor, LDR sensor, and solar panel are placed on the roof of the miniature house to save energy, and the stepper motor to move the roof is placed on the front side of the house. Meanwhile, the Arduino Uno is placed inside the miniature house. The combined prototype can be seen in Figures 7 and 8 below:



Figure 7. Top view Prototype



Figure 8. Front view Prototype

* Morina Buulolo, et al



This is anCreative Commons License This work is licensed under a Creative Commons Attribution-NonCommercial 4.0 International License.

3.1.2 Component testing

The testing process was conducted to obtain operational data from the prototype device and to determine the reliability and shortcomings of the device's operating system. The following are some of the component tests performed:

1. Rain sensor testing

This test aims to ensure there are no errors in the commands and the resulting output. The test is performed by applying water droplets to the rain sensor panel. The test can be seen in figure 9 below:

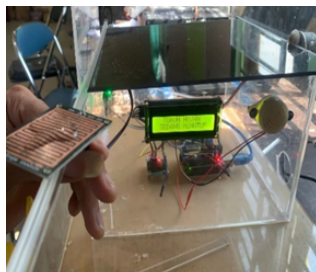

Figure 9. Rain Sensor Testing Process

From the tests that have been carried out in the image above, the test results can be obtained in table IV.2 below:

Tabel 2. Rain Sensor Test Results

No	Test Series	Test Results	Description
1	Water is Dripped onto the surface of the rain sensor	The sensor detects the presence of water, The roof is closed	Success
2	Water droplets are wiped off the surface of the rain sensor with a cloth	The sensor detects no water, the roof is open	Success
3	Wet tissue is palced on the surface of the rain sensor	The sensor detects the presence of water,the roof is closed	Success
4	Wet tissue is lifted from the surface of the rain sensor	The sensor detects no water, the roof is open	Success

From the test results in Table 2, it was found that the rain sensor can capture light intensity well in all experiments.

2. Light Sensor Testing

The light sensor or LDR (Light Dependant Resistance) test is performed to determine the sensor's performance in the presence of light intensity. The test is performed by covering the light sensor with your hand several times to detect darkness or night and pointing the sensor directly at light to detect light. The test can be seen in Figure 10 below:

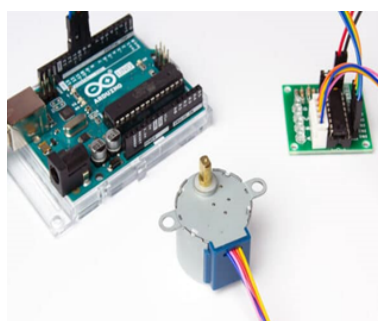

Figure 10. Light Sensor Testing Process

* Morina Buulolo, et al



From the tests that have been carried out in the image above, the test results can be obtained in table 3 below:

Table 3. Light Sensor Test Results

No	Test Series	Test Results	Description
1	Lighth sensor is covered using hand	Sensor detects no light, roof closed	Success
2	Hand released on light sensor	The sensor detects that there is light, the roof is open	Success
3	The light sensor is covered using paper	Sensor detects no light, roof closed	Success
4	The cover paper is removed on the light sensor	The sensor detects that there is light, the roof is open	Success
5	The light are turned off	Sensor detects no light, roof closed	Success
6	The flashlight is directed at the surface of the light sensor	The sensor detects that there is light, the roof is open	Success

From the test results in Table 3, it was found that the light sensor can capture light intensity well in all experiments.

3. Stepper Motor Testing

Stepper motor testing is performed to determine whether the servo is functioning properly. Stepper motor testing uses an Arduino to give commands to the stepper motor. The test can be seen in Figure 11 below:

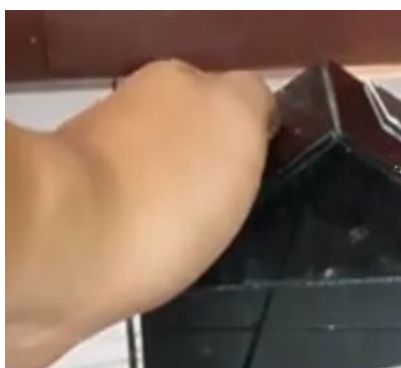

Figure 11. Stepper Motor testing Process

From the tests that have been carried out on the stepper motor, the test results obtained can be seen in table 4 below:

Table 4. Stepper Motor Test Results

No	Test	Test results	Result
1	Stepper Motor ON	Stepper Motor moves to an angle 90 ⁰	Success
2	Stepper Motor OFF	Stepper Motor moves to an angle 0 ⁰	Success
3	Stepper Motor ON	Stepper Motor moves to an angle 90 ⁰	Success
4	Stepper Motor OFF	Stepper Motor moves to an angle 0 ⁰	Success
5	Stepper Motor ON	Stepper Motor moves to an angle 90 ⁰	Success
6	Stepper Motor OFF	Stepper Motor moves to an angle 0 ⁰	Success

The stepper motor test results show that it is working properly and can move as desired. The results of the test, which will determine whether the stepper motor is functioning or not on the roof, are displayed on the LCD screen, as shown in Figures 12 and 13 below:

* Morina Buulolo, et al



This is anCreative Commons License This work is licensed under a Creative Commons Attribution-NonCommercial 4.0 International License.



Figure 12. Roof Status Display is Closing



Figure 13. Roof Status Display While Opening

4. Solar Panel Testing

Solar panel testing is performed to determine whether it is functioning properly. The test involves shining a light on the solar panel several times. The test can be seen in Figure 14 below:

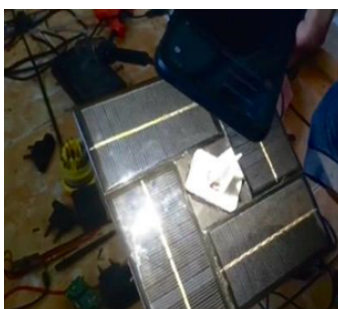

Figure 14. Solar panel Testing Process

From the tests that have been carried out on solar panels, the test results obtained can be seen in table 5 below:

Table 5. Testing Results of Solar Panels

No	Test suite	Test Results	Keterangan
1	Solar panels are directed towards sunlight	Solar panel work by storing light energy	Success
2	The adapter is removed from the sket to stop the electrical energy	Solar panel work and the equipment remains operational	Success
3	The flashlight is directed at the surface of the solar panel	Solar panel operate by following the light of a flashlight	Success
4	The electricity is off, it's night time	Light sensor detects no light, roof closed	Success

From the test results on the solar panel, it can be seen that the panel works well and can move as desired.

* Morina Buulolo, et al







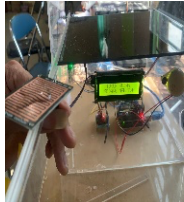

This is anCreative Commons License This work is licensed under a Creative Commons Attribution-NonCommercial 4.0 International License.

3.1.3 Blackbox Testing

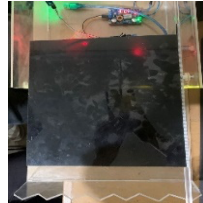
The tool is tested using the black box method to check whether the tool's function is running properly or whether there are still errors in the tool being created. By finding errors and deficiencies, this testing helps in maintaining the program code and provides recommendations for further development in the future [5]. The following are several stages of testing carried out:

Table 6. Blackbox Test Results

No	Condition	Test Scenarios	Tes Case	Expected results	Test Results
1.	Rain, Afternoon	Water is dripped on the rain sensor		Roof closes automatically	 Success
2.	Rain, Night	Water is dripped on the rain sensor, the light sensor is covered by hand.		Automatically Closed Roof	 Success
3.	Bright Evening	Rain sensor is not dripped with water, Light sensor is covered by hand		Automatically Closed Roof	 Success
4.	Sunny, Afternoon	The rain sensor is not dripped with water and the light sensor is not covered.		The roof opens automatically	 Success

DISCUSSIONS

In this stage, we will discuss the working principles of the automatic clothesline using the FR-04 sensor, as follows:

- The system is equipped with rain and light sensors to detect weather conditions.
- An Arduino Uno processes data from the sensors and sends commands to the stepper motor.
- The stepper motor is used to move the clothesline. When the system detects rain, the motor closes the clothesline, and when it detects sunlight, the motor opens the clothesline.
- The LCD display the conditions when the clothesline opens and closes..
- A buzzer sounds to indicate whether the clothesline is open or closed.

* Morina Buulolo, et al



CONCLUSION

After analyzing and evaluating the thesis entitled "Implementation of the FR-04 Sensor for Automatic and Energy-Efficient Control of a Clothesline Roof," the author can draw several conclusions. These conclusions are as follows:

- a. The automatic clothesline roof system designed using the FR-04 sensor has successfully identified and resolved problems with drying clothes that are typically done manually.
- b. If it rains during the day, the roof will close; at night, whether it's rainy or dry, the roof will close. Conversely, during sunny days, the roof will open.
- c. This device is designed using components such as an Arduino, a rain sensor, a light sensor (LDR), an FR-04 rain sensor, a stepper motor, and a 16 x 2 LCD. The light sensor detects light based on its intensity. The rain sensor detects water hitting the sensor and then sends a signal to the Arduino, which activates the stepper motor to move to a predetermined position, allowing it to open and close. Information about the open and closed roof and weather conditions is then displayed on the 16 x 2 LCD.

REFERENCES

- Alfiansyah, M. N., & Nugroho, A. (2023). Automatic clothesline control system using rain and light sensors for energy efficiency. *International Journal of Electrical and Computer Engineering (IJECE)*, 13(1), 657–665. <https://doi.org/10.11591/ijece.v13i1.pp657-665>
- Arfianto, D. (2021). Prototipe jemuran otomatis dengan sensor hujan, LDR berbasis Arduino Uno R3 dan sistem monitoring menggunakan aplikasi Blynk. *Seminar Nasional Manajemen, Informatika, dan Komputer (SENAMIKA)*, 269–277. <https://ejournal.teknokrat.ac.id/index.php/senamika/article/view/1230>
- Fedianto, M. H. S., Aditiawan, F. P., & Al Haromainy, M. M. (2023). Pengujian sistem jaringan dokumentasi dan informasi menggunakan black box testing dan white box testing. *Jurnal Publikasi Sistem Informasi dan Manajemen Bisnis*, 3(1), 213–221. <https://doi.org/10.55606/jupsim.v3i1.2447>
- Fitria, D., & Hidayat, A. (2022). Pengembangan sistem atap jemuran otomatis dengan sensor FR-04 dan konektivitas Blynk berbasis IoT. *Jurnal Teknologi Rekayasa dan Inovasi*, 4(3), 145–153. <https://journal.inovasi.tech/index.php/jtri/article/view/895>
- Hafidhin, M. I., Saputra, A., Rahmanto, Y., & Samsugi, S. (2020). Alat penjemuran ikan asin berbasis mikrokontroler Arduino UNO. *Jurnal Teknik dan Sistem Komputer*, 1(2), 59–66. <https://doi.org/10.33365/jtikom.v1i2.210>
- Jadhav, R. S., & Deshmukh, P. B. (2020). Design and development of an automated clothes drying system using IoT and environmental sensors. *International Research Journal of Engineering and Technology (IRJET)*, 7(5), 3172–3178. <https://www.irjet.net/archives/V7/i5/IRJET-V7I5661.pdf>
- Kencana, W., A. G. A. T. H. A., & Dan, F. T. I. (2020). Rancang bangun alat otomatis hand sanitizer dan ukur suhu tubuh mandiri untuk pencegahan Covid-19 berbasis IoT. *Jurnal Transit*, 1–6. <https://ojs.trigunadharma.ac.id/index.php/transit/article/view/1226>
- Kumar, A., & Gupta, R. (2020). IoT-enabled smart home energy-saving roof control system. *International Journal of Innovative Technology and Exploring Engineering (IJITEE)*, 9(6), 120–125. <https://doi.org/10.35940/ijitee.F3795.049620>
- Li, X., Wang, S., & Zhao, Y. (2022). Smart IoT-based rain detection and automatic awning control system for household energy saving. *Sensors*, 22(14), 5318. <https://doi.org/10.3390/s22145318>
- Luo, H., Chen, W., & Li, P. (2021). Design of an automatic retractable roof system using IoT-based rain sensors and servo control. *Measurement*, 180, 109559. <https://doi.org/10.1016/j.measurement.2021.109559>
- Mustar, R. O. W. M. Y. (2017). Implementasi sistem monitoring deteksi hujan dan suhu berbasis sensor secara real time. *Semesta Teknik*, 20(1), 20–28. <https://jurnal.umj.ac.id/index.php/semesta/article/view/1865>
- Nguyen, T. P., & Le, H. N. (2021). Energy-efficient automatic roof control for smart homes using IoT sensors and adaptive algorithms. *Journal of Building Engineering*, 44, 103240. <https://doi.org/10.1016/j.jobee.2021.103240>
- Nurhasanah, L., & Ramadhan, M. (2023). Penerapan sensor FR-04 dan LDR pada sistem atap otomatis hemat energi menggunakan ESP32. *Jurnal Riset Teknologi Elektro dan Komputer*, 8(1), 33–42. <https://ejournal.teknokrat.ac.id/index.php/jrtek/article/view/2180>

- Prasetyo, Y., & Zainuddin, A. (2020). Smart clothesline roof system based on FR-04 rain sensor and solar power controller. *Jurnal Teknologi Informasi dan Elektronika*, 5(4), 201–210. <https://ejurnal.poliban.ac.id/index.php/jtie/article/view/1117>
- Putra, A. P., & Wicaksono, D. (2022). Perancangan sistem jemuran otomatis berbasis Internet of Things menggunakan sensor FR-04 dan NodeMCU ESP8266. *Jurnal Teknologi dan Sistem Terkini*, 3(2), 101–110. <https://doi.org/10.33365/jst.v3i2.1142>
- Rahman, M., & Anwar, S. (2023). IoT-based automatic roof control system using rainfall and humidity sensors for household energy saving. *IEEE Access*, 11, 45327–45338. <https://doi.org/10.1109/ACCESS.2023.3267554>
- Setiawan, F., & Haryanto, R. (2021). Sistem pengendali atap otomatis berbasis sensor hujan FR-04 dan sensor cahaya LDR dengan Arduino UNO. *Jurnal Elektro dan Instrumentasi*, 7(2), 88–95. <https://jurnal.untidar.ac.id/index.php/jei/article/view/2230>
- Sutanto, D., & Priyanto, A. (2022). Analisis kinerja sensor FR-04 dalam mendeteksi intensitas hujan pada sistem otomatisasi berbasis mikrokontroler. *Jurnal Teknik Elektro Indonesia*, 12(1), 55–63. <https://doi.org/10.22146/jtei.v12i1.9803>
- Taufik, M., & Rachman, A. (2021). Rancang bangun sistem atap jemuran otomatis menggunakan sensor hujan FR-04 berbasis Arduino Uno. *Jurnal Teknik Elektro dan Komputer*, 10(3), 112–119. <https://doi.org/10.33369/jtekkom.v10i3.1789>
- Zhang, Y., & Liu, C. (2024). IoT-based automatic rain detection system for smart domestic control applications. *IEEE Internet of Things Journal*, 11(2), 14012–14020. <https://doi.org/10.1109/JIOT.2024.3360124>